



GW-T

Wedge grips 20kN and 50kN

Multi purpose, self-tightening grips.

Suitable for metal or plastic specimens (with medium strength) etc.

Easy to use: The grips feature a lever arm for quick loading and releasing of the samples.

The wedge-shaped design of the jaws causes the clamping force to increase, as tension is applied during the test.



GW-50T

GW-20T

Item No.	GW-20T	GW-50T
Tensile force	20 kN	50 kN
Temperature range	0°C - +130°C (GW-20T) -70°C - +280°C (GW-20T-Ni) -70°C - +280°C (GW-20T+TK Option)	0°C - +130°C (GW-50T) -70°C - +280°C (GW-50T-Ni) -70°C - +280°C (GW-50T+TK Option)
Body	Steel, phosphate coated (GW-20T) Steel, nickel plated (GW-20T-Ni)	Steel, phosphate coated (GW-50T) Steel, nickel plated (GW-50T-Ni)
Weight	3.8 kg each grip (without jaws)	6.75 kg each grip (without jaws)



GW-20T-Ni

Wedge jaws for GW-T grips: scope of delivery 1 set = 4 jaws

Item No.	Surface	Clamping surface H x W	Opening	Weight per pair
GW-T-BP	Pyramid (serrated) jaws	50 x 35mm	0 – 13mm	0.48 kg
GW-T-BP16	Pyramid (serrated) jaws	50 x 35mm	4 – 16mm	0.41 kg
GW-T-BV	V-jaws	Clamping height 50mm	3 – 13mm Ø	0.46 kg
GW-T-BV16	V-jaws	Clamping height 50mm	4 – 16mm Ø	0.41 kg

Jaws with other dimensions and surface coatings on request

	<p>GW-T-BP Pyramid jaws</p> <ul style="list-style-type: none"> • Hardened steel 58 HRC • Pyramids 1.2 x 45° 		<p>GW-T-BV -V-jaws</p> <ul style="list-style-type: none"> • For all kinds of round samples • Hardened steel 58 HRC • Tooth pitch 1.2 mm
--	---	--	--



GW-20T+TK Option
(for GW-20T and GW-50T)

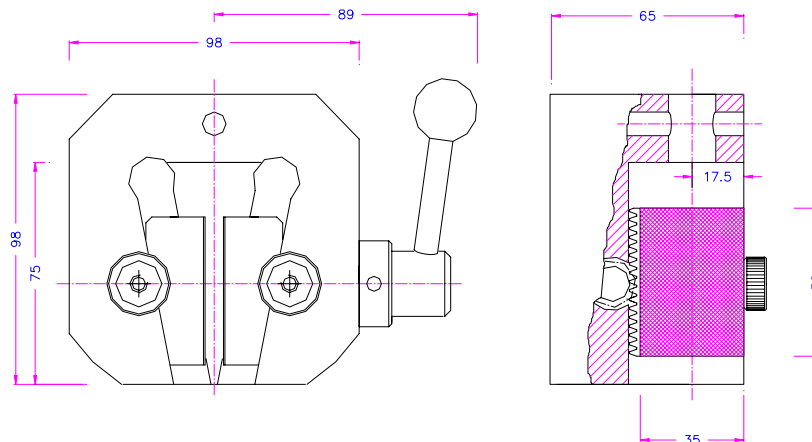

GW-20T

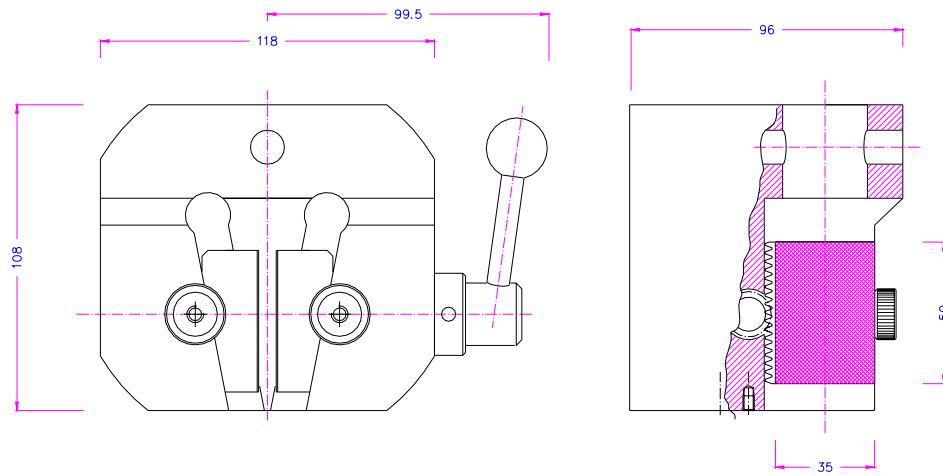

GW-50T

Examples of other versions and custom built solutions



Ordering information

GW-T grips are supplied as a pair, but can also be ordered separately (0.5 pair). Grips and jaws need to be ordered separately.